

High quality motors and materials guarantee a smooth operation with each model of this range. Easy maintenance and service works are additional features of this attachment. The compactors provide for an efficient and high compacting performance thanks to their large compactor plates and high impulse energy.

Ideal also in combination with a **NOX** Tiltrotator.

- ▶ Long service life with low maintenance costs.
- ▶ High impulse energy thanks to the use of high quality motors.
- ▶ Optionally including 2 x 100° rotation.

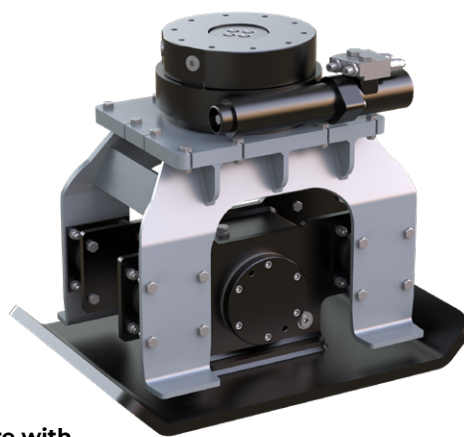

here with RD12 rotation

Hydraulic Compactors KHC

Type	Compactor plate size (A x B) (mm)	Height C (mm)	Compacting force (t)	Frequency (U/min)	Weight w/o adapter (kg)	Operating weight (t)
KHC08	730 x 318	473	1,5 - 2,5	2500	225	4 - 8
KHC12	920 x 600	537	2 - 3	2400	290	7 - 12
KHC16	1120 x 750	685	7 - 8	2200	650	10 - 16

Package consists of: compactor

Accessories

Type	Description
RD12 add	2 x 100° rotation (surcharge)
KHC blade	blade for moving soil
KM 690 8t	adapter for rigid mounting – up to 8t
KM 690 15t	adapter for rigid mounting – up to 15t
KM 691 8t	adapter plate for specific solutions – up to 8t
KM 691 15t	adapter plate for specific solutions – up to 15t
KSW03 rigid	bolt-on-adapter for system L-Lock KMS03L/KHS03L for rigid mounting – up to 6t
KSW08 rigid	bolt-on-adapter for system L-Lock KMS08L/KHS08L for rigid mounting – up to 12t
OQ45/3 rigid	bolt-on-adapter for Oilquick OQ45 – 5t up to 12t
	adapters for quick change systems from other manufacturers or different sizes available on request

Requirements of carrier machine

Type	KHC08	KHC12	KHC16
Operating pressure:	170-200 bar	90-130 bar	130-170 bar
Recommended pump capacity:	30-50 l/min	70-130 l/min	110-140 l/min

Technical drawing

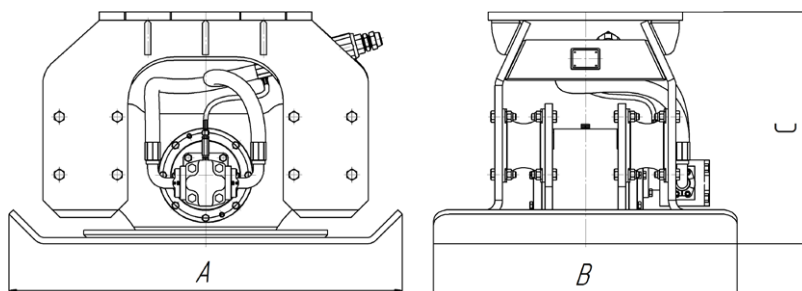

here with NOX Tiltrotator

High quality motors and materials guarantee a smooth operation with each model of this range. Easy maintenance and service works are additional features of this attachment. The compactors provide for an efficient and high compacting performance thanks to their large compactor plates and high impulse energy.

Ideal also in combination with a **NOX** Tiltrotator.

- ▶ Long service life with low maintenance costs.
- ▶ High impulse energy thanks to the use of high quality motors.
- ▶ Optionally including 2 x 100° rotation.

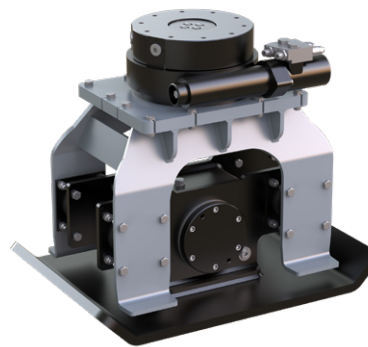

here with rotation

Hydraulic Compactor KHC

Type	Compactor plate size (A x B) (mm)	Height C (mm)	Compacting force (t)	Frequency (U/min)	Weight w/o adapter (kg)	Operating weight (t)
KHC16	1120 x 750	685	7 - 8	2200	650	10 - 16
KHC25	1270 x 950	765	9 - 11	2000	840	14 - 25
KHC35	1290 x 1000	765	10 - 15	2000	1020	18 - 35
KHC40	1500 x 1000	826	15 - 20	2200	1350	30 - 40

Package consists of: compactor

Accessories

Type	Description
RD12 add	2 x 100° rotation (surcharge)
KHC blade	blade for moving soil
KM 690 15t	adapter for rigid mounting – up to 15t
KM 690 20t	adapter for rigid mounting – up to 20t
KM 690 27t	adapter for rigid mounting – up to 27t
KM 690 32t	adapter for rigid mounting – up to 32t
KM 690 40t	adapter for rigid mounting – up to 40t
KM 691	adapter plate for specific solutions – up to 27t available
KSW08 rigid	bolt-on-adapter for system L-Lock KMS08L/KHS08L for rigid mounting – up to 12t
KSW10 rigid	bolt-on-adapter for system L-Lock KMS10L/KHS10L for rigid mounting – up to 19t
KSW21/25 rigid	bolt-on-adapter for system L-Lock KMS21/25L / KHS21/25L – up to 40t
OQ	bolt-on-adapter for Oilquick – up to 70t available
	adapters for quick change systems from other manufacturers or different sizes available on request

Requirements of carrier machine

Type	KHC16	KHC25	KHC35	KHC40
Operating pressure:	130-170 bar	130-170 bar	150-190 bar	250-300 bar
Recommended pump capacity:	110-140 l/min	130-160 l/min	150-170 l/min	260-280 l/min

Technical drawing

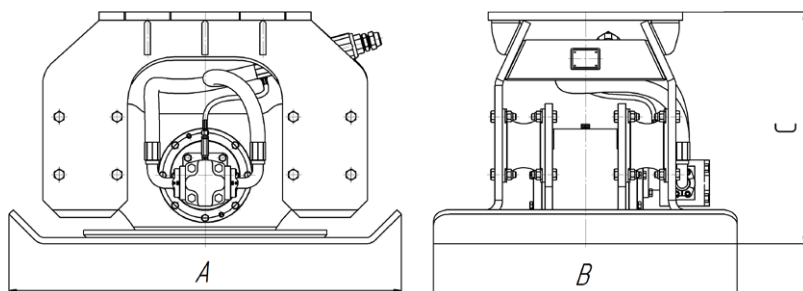

KHC16 here with NOX Tiltrotator