

The SP20H Double Ballast Plough is the ideal tool to collect or spread ballast and gravel – for road rail excavators from 14t - 24t / 30800 - 52800 lbs operating weight.

- ▶ **Easy to use:** the plough is pushed along the track on the rails while distributing the ballast evenly on the track.
- ▶ **For different loose materials** such as gravel, ballast, etc.
- ▶ **Adjustable plough depth** (4 x adjustable).
- ▶ **Different couplings** available.
- ▶ **Robust construction** without protruding parts.
- ▶ **Side flaps tilttable** ± 45°.

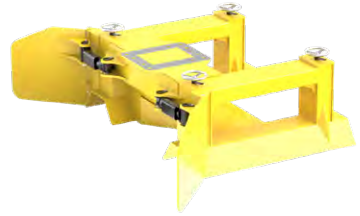

Double Ballast Plough SP20H

Type	Weight (kg / lbs)	Length B max. (mm / in)	Height C (w/o coupling) (mm / in)	Width E max. (mm / in)	For rail distance (mm / in)	Tilt angle side flaps (°)
SP20H	1150 / 2530	2120 / 83.46	750 / 29.53	3200 / 125.98	1505 / 59.25	± 45

Package consists of: double ballast plough

Accessories

Type	Description
T650 rigid	bolt-on adapter for "Atlas" quick coupler T620
Note:	see more mounting options page 27

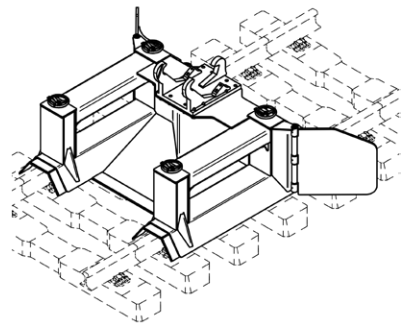
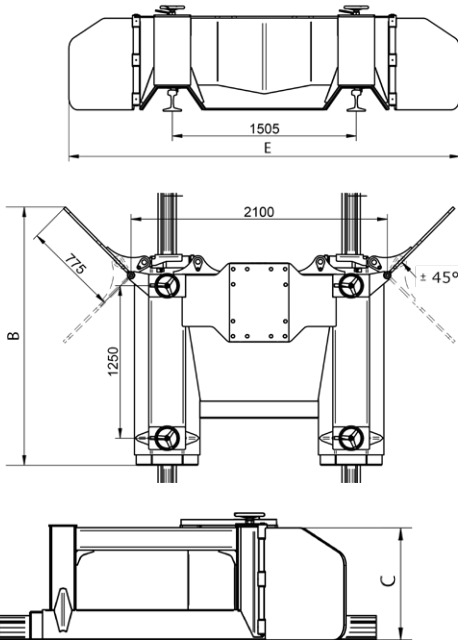

below:
with lateral flaps folded away

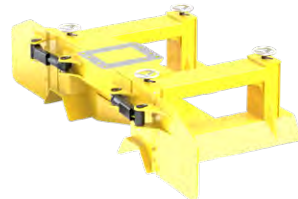

Requirements of Excavator

Three hydraulic circuits or two hydraulic circuits plus one solenoid valve needed

Operating pressure tilt flaps

max. 20 - 32 MPa (200 - 320 bar) / max. 2880 - 4608 psi

Recommended oil flow tilt flaps

50 - max. 75 l/min / 13.21 - max. 19.82 GPM